

SRFfg 3501

12 cu.ft. Performance Flammable Material Storage Refrigerator



Super-efficient

Rising electricity prices are increasing the demands on the efficiency of refrigerators and freezers. From the compressor to the seal, to the lighting and electronics, Liebherr fully utilizes the savings potential of every component. The result is impressive – especially in terms of total operating costs.

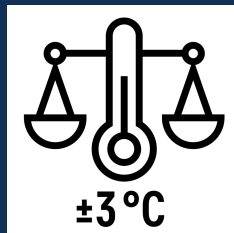

±3 °C temperature stability

Temperature fluctuations must be minimal to ensure that the quality of sensitive substances is preserved. Liebherr Laboratory refrigerators have an impressive maximum deviation of just ±3 °C from the set temperature. This not only maintains the storage climate, but also the value of your stored goods.



Complies with applicable requirements of NFPA 45 and NFPA 99

Complies with the applicable requirements for flammable material storage of NPA 45 and NFPA 99. The interior of Liebherr refrigerators and freezers for flammable storage material, is free of sources of ignition, used for storing flammable substances in closed containers, meets the requirements for **Class 1, Division 2** for storage of flammable materials equivalent of Gas Group B.



Self-closing door < 60°

To make loading, unloading and cleaning easier, the appliance door stays open if opened by more than 90°. If the opening angle is less than 60°, it closes automatically for safety.

LIEBHERR

SRFfg 3501

12 cu.ft. Performance Flammable Material Storage Refrigerator

Flammable Material Storage Refrigerator

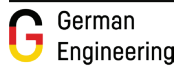

home.liebherr.com



SRFfg 3501	
Total gross/net capacity	12.1 / 11.1 cu. ft. (344 / 315 l)
Exterior dimensions in mm (w/d/h) in inches (w/d/h)	597 / 654 / 1684 23 9/16" / 25 3/4" / 66 5/16"
Interior dimensions in mm (w/d/h) in inches (w/d/h)	460 / 423 / 1460 18 1/8" / 16 11/16" / 57 1/2"
Energy Consumption (kWh/day) *	0.63
EnergyStar rated	Yes
Ambient temperature in °C (°F)	*+10 °C to +35 °C (+50 °F to +95 °F)
Heat output	388 kJ/h
Refrigerant	R 600a
Sound rating**	48 dB(A)
Voltage/ Frequency	115 V / 60Hz
Cooling system / Defrost	Forced-air/automatic
Temperature range in °C (°F)	*+3 °C to +16 °C (+38 °F to +60 °F)
Gradient / max. fluctuation	3.6 °C / 3.1 °C
External cabinet finish	Steel/white
Door/lid material	Steel
Internal liner material	Commercial grade molded polystyrol
Type of control	Monochrome display, touch buttons
Power failure alarm	When mains power return
Fault: warning signal	Visual and audible
Volt-free alarm contact	Yes
Connectivity type	SmartModule
Connectivity solution	Retrofittable
Interface	WiFi/LAN (optional)
Adjustable shelves	4
Shelf material	Glass
Usable Shelf Area in mm (w / d)	460 / 537
Shelf load weight in kg (lbs)	40 (88.2)
Handle	Antimicrobial handle with opening mechanism
Access ports	1 x Ø 10 mm
NFPA 45 and NFPA 99	Yes
Type of lock	Mechanical
Door Hinges	Right, reversible on site
Net weight	66 kg (145.5 lbs)

Unit Dimensions

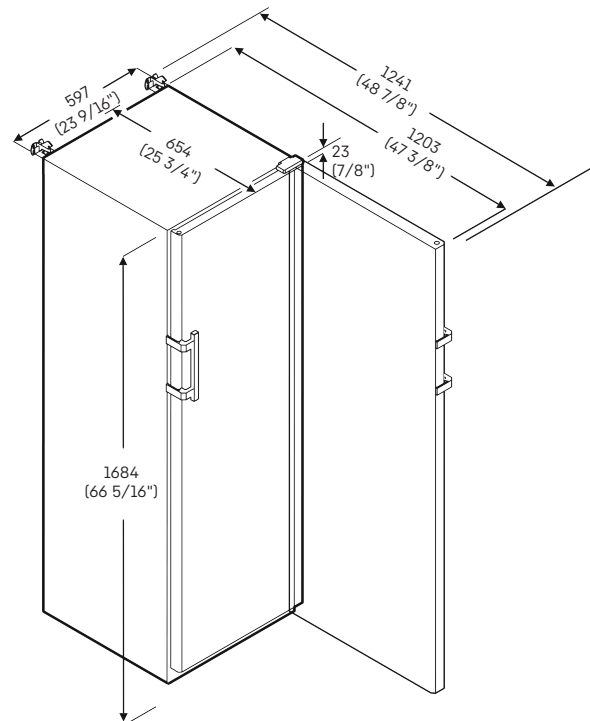

Accessories

Glass shelf	9293493
Scanner rail	7435208
Castors Ø 80 mm (3 in)	9086926
Castors Ø 100 mm (4 in)	9080023
Adjustable feet, 90 – 120 mm (3.5- 4.75 in)	9080022
Adjustable feet, 150 – 180 mm (5.9 - 7 in)	9086924
Side-By-Side kit	9017739
SmartModule	6145269

* Measured unloaded at 26.6°C (80°F) ambient temperature with set point of 3.3°C (38°F).

** Noise level – sound power re 1pW – according to IEC 60704-2-14.